

Det Kgl. Danske Videnskabernes Selskab.  
Mathematisk-fysiske Meddelelser. **XIX**, 2.

---

# CONSTRUCTION OF A CYCLOTRON

(INSTITUTE FOR THEORETICAL PHYSICS, COPENHAGEN)

BY

J. C. JACOBSEN



KØBENHAVN

I KOMMISSION HOS EJNAR MUNKSGAARD

1941

## CONTENTS

	Page
Introduction .....	3
Cyclotron Principles .....	5
The Magnet .....	11
The Oscillator .....	17
The Tank .....	19
The Dees .....	24
Working Experiences .....	27

---

## Introduction.

The ingenious construction by LAWRENCE of an electromagnetic resonance-accelerator for high-speed ions, the so-called cyclotron, has, as well known, been of great importance for the recent development in nuclear physics. By means of the cyclotron one can in fact obtain intense beams of ions with energies considerably greater than has hitherto been possible with high tension installations, where the ions are accelerated in one step. Even though the cyclotron cannot yet produce ion-beams with energies as well defined as those obtainable from high tension apparatus, it thus constitutes a most important auxiliary for the extension of the field of nuclear researches. When a few years ago by grants to Professor BØHR from the Carlsberg Foundation and the Rockefeller Foundation it became possible to acquire the means for enlarging the scope of such researches in this Institute, it was therefore planned besides a one million volt high tension installation<sup>1</sup> to build a cyclotron of a size enabling us to work with deuteron beams having energies up to ten million volts.

The realisation of this plan was above all made possible by a gift from the Thrige Foundation of a suitable magnet

<sup>1</sup> T. BJERGE, K. J. BROSTRØM, J. KOCH and T. LAURITSEN, A high tension apparatus for nuclear research. D. Kgl. Danske Vidensk. Selskab, Math.-fys. Medd. XVIII. 1. (1940).

with an iron core of 35 tons, the successful construction of which we owe to director V. MEYER of the Ths. B. Thrige factories, Odense, Denmark. For our work it has further been of greatest importance that Professor LAWRENCE himself has taken a most kind interest in our plans and has not only provided us with detailed drawings of his own constructions, but also was helpful in securing the invaluable assistance of one of his own collaborators, Dr. L. J. LASLETT, who stayed here one and a half year as stipendiary of the Rockefeller Foundation and the Rask-Ørsted Foundation.

The first beam from the cyclotron was obtained already in 1938 but, to begin with, the intensity was small and energies of only a few million volts could be reached. After various improvements of the apparatus the intensity of the beam was gradually increased and the cyclotron has in the course of the last years been in extensive use as a source of radioactive isotopes for the physico-biological investigations carried out in this Institute by Professor G. HEVESY and his collaborators. In the meantime greater energies were also obtained and in the summer of 1940 deuteron beams of ten million volts were successfully applied to the fission of uranium and thorium.<sup>1</sup> Although various further improvements of the cyclotron are under preparation, the apparatus has now been so long in function that it may be of interest to give an account of the experience gained with the present construction which in certain details differs from the construction of other cyclotrons described hitherto.

<sup>1</sup> J. C. JACOBSEN and N. O. LASSEN, Phys. Rev. **58**, 867 (1940).

### Cyclotron Principles.

The principles underlying the construction of the cyclotron have been described by LAWRENCE and his co-workers<sup>1</sup>, but for the sake of completeness the general formulae may be repeated here.

A charged particle with mass  $m$  and charge  $e$  is supposed to move with velocity  $v$  in a magnetic field  $H$  perpendicular to the lines of force. The radius  $r$  of the circular path is determined by

$$\frac{mv^2}{r} = e \cdot v \cdot H.$$

The time required for a complete revolution is

$$\tau = \frac{2\pi r}{v} = 2\pi \frac{m}{eH} \quad (1)$$

and is, thus, independent of the velocity of the particle as long as  $m$  remains constant.

To accelerate the ions, two radio frequency electrodes are used, each semicircular in shape and hollow; they are mounted in a vacuum chamber between the poles of a magnet so that the lines of force are perpendicular to the plane of the electrodes.

Between the electrodes (in the following referred to as the dees) a high frequency voltage difference is maintained.

Ions moving in the interior of the dees are accelerated in passing the diametral gap between the dees; if the period of oscillation of the high frequency source is equal to the time of revolution given by (1) the ions will remain in the

<sup>1</sup> E. O. LAWRENCE and EDLEFSON, *Science* **72**, 376 (1930); E. O. LAWRENCE and M. S. LIVINGSTON, *Phys. Rev.* **40**, 19 (1932); E. O. LAWRENCE and M. S. LIVINGSTON, *Phys. Rev.* **45**, 608 (1934); E. O. LAWRENCE and COOKSEY, *Phys. Rev.* **50**, 1131 (1936).

same phase relative to the high frequency potential difference between the dees and, as a consequence of successive accelerations, will move in a series of ever widening semi-circular paths. The number of accelerations may be very large, so that the energy finally obtained may be many times greater than the potential difference between the dees.

If  $\lambda$  is the wavelength of the high frequency source, the condition for resonances is

$$\frac{\lambda}{c} = 2\pi \frac{m}{e \cdot H}. \quad (2)$$

For deuterons and a field of about 15 000 Ørsteds, this gives for  $\lambda$  a value of about 25 metres.

The energy finally attained by the ions depends upon the diameter of the dees. If  $r$  is the radius of the last semi-circle, the velocity of the ions is

$$v = \frac{e}{m} \cdot r \cdot H$$

and the energy

$$V = \frac{1}{2} \frac{e}{m} \cdot r^2 \cdot H^2 \cdot 10^{-8}. \quad (3)$$

Here,  $V$  is expressed in electron volts,  $\frac{e}{m}$  and  $H$  in e. m. units. To obtain a high energy, both  $r$  and  $H$  must be made large. In practice, however, magnetic fields larger than about 20 000 Ørsteds are very expensive to maintain; a further restriction on the magnetic field is imposed by the circumstance that it has been found necessary to have a possibility for applying local corrections to the field, and these corrections can only be made if the steel of the pole pieces is not too near saturation. The result is that fields higher than about

17 000 Ørsteds can hardly be used. With this value of  $H$ , the value of  $r$  necessary to produce deuterons with 10 MeV energy is  $r = 37$  cm. As a consequence of the restrictions imposed on the magnetic field, the only way of increasing the energy seems to be an increase of the radius of the dees.

Inherent in the resonance principle is a feature which gives a high intensity of the ion beam, viz. that the resonance condition is independent of the momentary value of the potential difference between the dees. Disregarding for the moment the focussing conditions which will be considered later, this means essentially that the whole of the half-cycle of the high frequency is utilized.

Targets to be irradiated may be inserted in the diametral gap between the dees. For non-volatile substances, this method yields good service in so far as the whole of the circulating ion beam is utilized but for substances which are likely to spoil the vacuum in the cyclotron it is necessary to remove the high energy ions from the space inside the dees into a separate bombarding chamber. For this purpose, an auxiliary electrode which is maintained at a constant negative potential is placed at a suitable distance from the cylindrical wall of one of the dees. The electrostatic force between the deflecting electrode and the wall of the dee will increase the radius of curvature of the beam and in this way make it possible to bring the beam outside the dee. Experience has shown that an increase of 15% in the radius of curvature is suitable; the electric field  $F$ , which is necessary, is calculated from

$$e \cdot F = 0.15 \cdot \frac{mv^2}{r} = 0.15 \cdot \frac{2eV}{r}, \text{ or}$$

$$F = 0.30 \cdot \frac{V}{r}.$$

For  $V = 10$  MeV and  $r = 38$  cm, this gives  $F = 80\,000$  volts per cm.

The distance between successive paths of an ion depends on the voltage difference between the dees. If  $\Delta V$  is the gain in energy per revolution, the distance  $\Delta r$  between successive paths is given by

$$\Delta V = 10^{-8} \cdot \frac{e}{m} \cdot H^2 \cdot r \Delta r;$$

for  $\Delta V = 70\,000$  volts, corresponding to a voltage difference of 35 000 volts between the dees,  $H = 17\,000$  Ørstedes and  $r = 38$  cm, giving for deuterons  $\Delta r = 0.12$  cm. The thickness of the cylindrical wall of the dee facing the deflecting electrode must be small compared to  $\Delta r$  in order to reduce as far as possible the loss of ions due to collisions with the wall.

The ions to be accelerated are produced near the centre of the cyclotron. In its simplest form, the ion source involves a beam of electrons projected vertically between the dees through hydrogen or deuterium gas at a low pressure. Although more efficient methods for the production of ions have been developed, this simple form of ion source has been used throughout in the present work. The number of ions produced depends on the gas pressure and the number and velocity of the electrons. The extension of the space between the dees inside which the ions are actually produced is determined partly by the final length of the filament used as a source of electrons and partly by the cycloidal motion carried out by the electrons under the combined action of the magnetic field and the electric field between the dees. In practice, the extension of the ion source is of the order



of a few centimetres; this feature is undesirable, because ions starting at different places will reach the deflecting field with different energies. Since, furthermore, the paths of different ions reaching the deflecting field are not parallel in space, a considerable loss of ions takes place during the passage through the deflecting field due to collisions with the deflecting electrode and the dee wall; in practice, the ion beam leaving the deflecting field amounts to roughly 10% of the beam inside the dees.

The complicated conditions arising when regard is taken to a possible asymmetry in the magnetic field are referred to later in connection with the measurements of the energy spread of the beam leaving the deflecting field.

In the simple resonance condition the magnetic field is supposed to be homogeneous. In practice, however, a magnetic field is used which is somewhat stronger at the centre than at the periphery, the difference in the field between the centre and the exit slit being of the order of 1%. This inhomogeneity involves the existence of a radial component of the field which, in turn, gives rise to a restoring force on the ions, the force being directed from both sides towards the plane of symmetry. If  $z$  is the distance from the plane of symmetry, and  $H_r$  is the radial component of the field, then

$$\frac{\delta H_z}{\delta r} = \frac{\delta H_r}{\delta z} \quad \text{or} \quad H_r = z \cdot \frac{\delta H_z}{\delta r} \propto z \cdot \frac{\delta H}{\delta r}.$$

The restoring force is, thus, proportional to the distance from the plane of symmetry and the ions, consequently, carry out oscillations on both sides of the plane of symmetry.

The electric field between the dees also gives rise to a focussing effect; the equipotential surfaces between the dees are located in such a way that the ions are subject to a force directed against the median plane before the passage of the gap and directed away from the median plane after the passage of the gap. Since the ions are accelerated, the latter force acts during a shorter time than the former and the result is a focussing effect. This sort of focussing is mainly effective near the centre of the cyclotron where the energy of the ions is small. For high energy ions, a different sort of electric focussing is effective, depending on the change in the voltage difference between the dees during the passage of the ions through the gap. A simple consideration will show that a focussing effect takes place if the voltage difference between the dees is decreasing while the ions pass through the gap. As a whole, the magnetic focussing is more important than the electric focussing, because the electric focussing is a differential effect whereas the magnetic forces act over the whole path of the ions. The focussing effects are extremely important in securing a high intensity of the ion beam. As a consequence of the focussing effects, a considerable fraction of the ions generated at the centre of the cyclotron is able to reach the edge of the dee without colliding with the top or bottom plates.

The desirability of employing a slightly inhomogeneous field involves that the actual field shows small deviations from the value  $H_{\text{res}}$  which fulfills the resonance condition (2). If it is assumed, as seems generally to be the case, that the actual field is stronger than  $H_{\text{res}}$  at the centre and weaker at the edge, the ions will gain in phase relative to the high frequency field between the dees during the first part of their path and lag behind in phase during the later

part<sup>1</sup>. A phase lag is further introduced by the relativistic change in mass which becomes effective for ions with high energy.

The existence of a phase lag sets an upper limit to the energy which can be obtained because, if the number of accelerations is increased beyond a given limit, the ions will be retarded and consequently lost.

The electric and magnetic focussing effects have been treated in detail by ROSE<sup>2</sup> and by WILSON<sup>3</sup>. For the phase lag just mentioned, ROSE has shown that it is inversely proportional to the voltage difference between the dees. In principle, there is thus no definite upper limit to the energy obtainable, the limitation being caused by the amount of power, only, which is available for the oscillator.

### The Magnet.

The magnet and the oscillator are placed in a room below ground level which is situated between the high tension hall and the main building of the Institute. The magnet is placed on a socket so that the gap is 1.5 m above the floor; this placement was originally done in order to have the gap nearly midway between the floor and the ceiling, so that in experiments with neutrons the scattering from floor and ceiling would be a minimum. In how far this precaution is justified remains to be seen;

<sup>1</sup> Here, it is assumed that the frequency of the oscillator is constant. For use in radio transmitters, methods have been developed for modulating the frequency of the oscillator and it might well be feasible to modulate the frequency of the oscillator in such a way that ions travelling through an inhomogeneous magnetic field would remain in exact resonance over their whole path.

<sup>2</sup> M. E. ROSE, *Phys. Rev.* **53**, 392 (1938).

<sup>3</sup> R. R. WILSON, *Phys. Rev.* **53**, 408 (1938).

up till now, all experiments with neutrons have been carried out with the target placed inside the tank wall. The oscillator is placed at a distance of 3 m from the magnet;

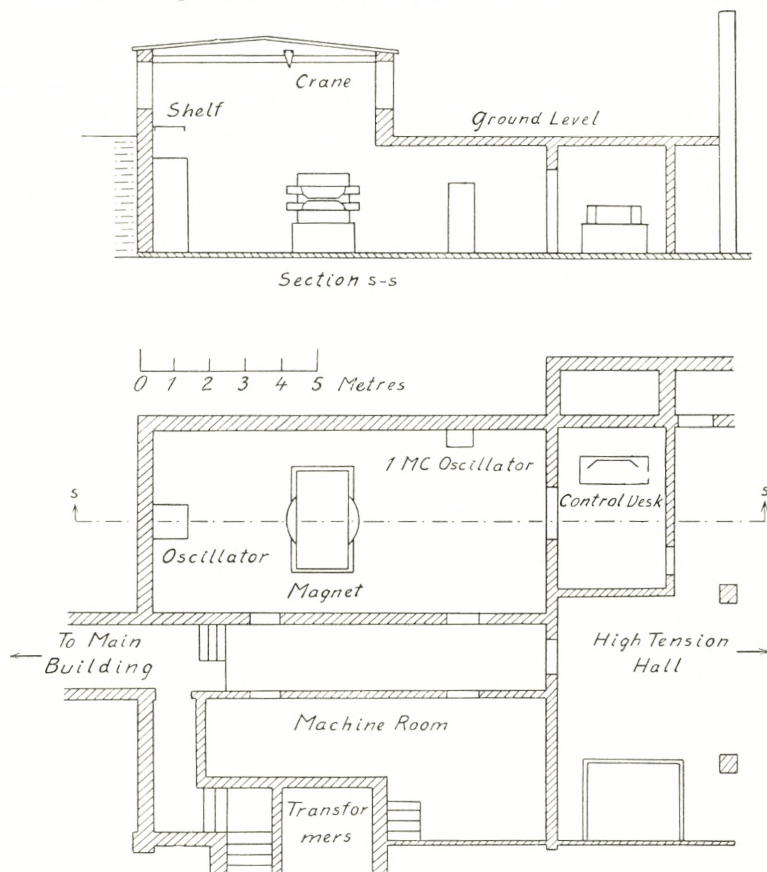

Fig. 1.

the anode voltage supply (a three-phase transformer with a six-phase rectifier) is placed on a shelf above the oscillator.

An adjacent room, which has been partitioned off from the high tension hall, contains the control desk with the main switchboard for the cyclotron.

The diameter of the pole faces is 90 cm, giving an area of  $63.7 \text{ dm}^2$ . From the face, the pole pieces are cylindrical for a height of 1 cm and, from this point, are tapered at an angle of  $45^\circ$  with the axis up to a diameter of 116 cm. From this height, the pole pieces are more nearly cylindrical, the diameter at the base of the pole piece is 119 cm, giving an area of  $110 \text{ dm}^2$ . The yoke

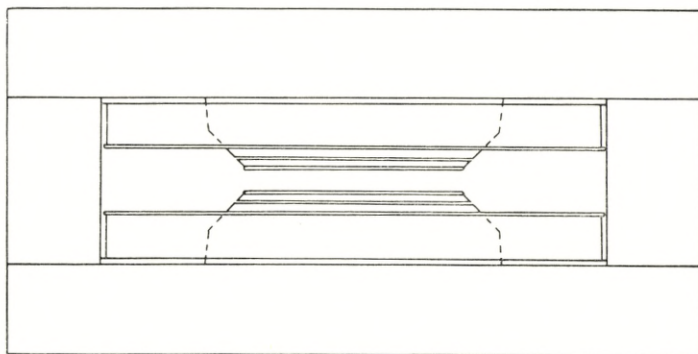

Fig. 2.

has a rectangular cross section with area  $55 \text{ dm}^2$ . The strongly tapered shape of the pole piece makes it possible to obtain high fields in the gap without undue saturation at the base of the pole piece. The highest field obtainable is about 20 000 Ørsted. To make possible the application of local corrections to the field ("shimming"), slits of 6 mm height are provided in the pole pieces at a distance of 4 cm from the faces.

The coils are flat "pancake" coils with 300 turns each, placed in oiltight tanks in transformer oil. The oil is circulated and cooled by water in a heat exchanger. The rate of exchange of heat between the oil and the water is such that, with 70 kW input into the coils, corresponding to a field of 20 000 Ørsted, the temperature becomes stationary

at about  $60^{\circ}\text{C}$ . The total weight of the magnet is 37 tons, including 3 tons of copper for the coils.

The power supply is a 250 volts d. c. generator driven by a 380 a. c. motor. The field of the d. c. generator is excited from a small d. c. generator. Manually controlled

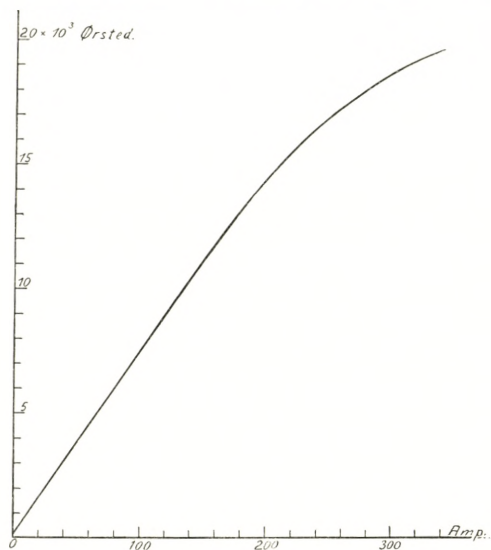

Fig. 3.

resistors serve for regulating the d. c. voltage. To reduce the effect of fluctuations in the supply from the a. c. mains, a device is used which is very similar to that published by PERRY<sup>1</sup>. This device will only compensate for fluctuations in the voltage across the coils of the magnet, so that the change in the current due to the gradual warming up of the coils must be compensated for by manual regulation.

The symmetry of the field about the median plane was tested by a small steel needle with a mirror fixed to it in the manner described by WILSON<sup>2</sup>. Small deviations

<sup>1</sup> T. PERRY, Phys. Rev. **53**, 943 (1938).

<sup>2</sup> R. R. WILSON, l. c.

were found, but it was estimated that symmetry could be established by shimming, a consequence which was verified when a beam had been obtained.

The radial gradient of the field was determined by a test coil (connected to a ballistic galvanometer) which could

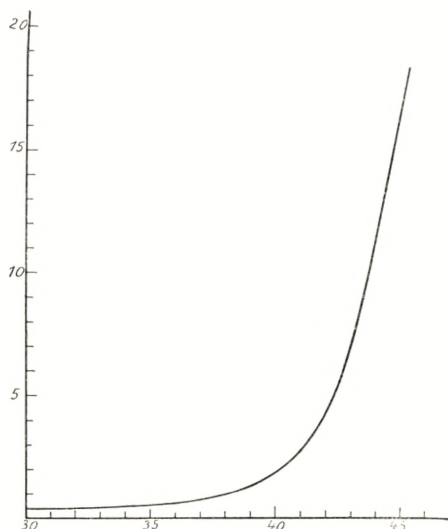

Fig. 4. Abscissa: distance from centre in cm. Ordinate: percentage deviation from field at centre.

be moved in steps along a diameter. The deflections were calibrated by a known mutual inductance.

In Fig. 3 is shown the variation of the field with the magnet current; Fig. 4 and Fig. 5 show at a somewhat different scale the field as a function of the distance from the centre. As ordinate, in Figs. 3 and 4, is plotted  $100 \cdot \frac{H_c - H_r}{H_c}$ , when  $H_c$  is the field at the centre and  $H_r$  the field at a distance  $r$  from the centre. When the tank is evacuated, the steel plates forming the top and the bottom of the tank are bent inwards; the displacement amounts

to 0.18 mm for each plate. When the magnet is excited, the plates are partly straightened out. Curve I in Fig. 4 shows the field with the tank evacuated and with air in the shimming gap, curve II was obtained with the shimming gap evacuated.

The results of Fig. 3 and Fig. 4 were obtained with a

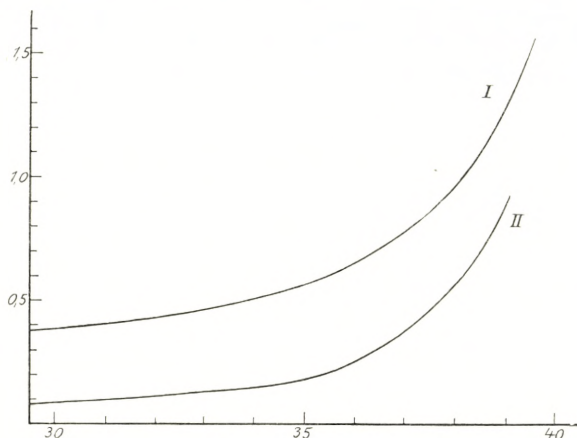

Fig. 5. Abscissa: distance from centre in cm. Ordinate: percentage deviation from field at centre.

field of 17 000 Ørsted. The quantity  $\frac{H_c - H_r}{H_c}$  varies little with  $H_c$ , so that almost the same curves represent the gradient at a field of 9 000 Ørsted.

To reduce the high frequency losses, the pole faces are plated with electrolytically deposited copper in a thickness of about 0.1 mm. After more than a year's use, most of the copper plating is apparently removed by sputtering from a region above and below the gap between the dees. Under these circumstances, the high frequency losses in the top and bottom plates amount to less than 10 per cent of the total energy expended in the tank circuit, as can be



shown by observing the rise in temperature of the plates when the cyclotron is running. So far, it has not been possible to decide whether the copper plating is actually of any use in reducing the losses in the tank circuit as a whole.

### The Oscillator.

The oscillator tubes are of the Sloan type and are continuously exhausted. The filament is a single hairpin loop of 1 mm tungsten wire with a total length of 47 cm, the anode cylinder is a  $2\frac{1}{2}$ " copper tube. The grid is wound from 1 mm copper wire with a spacing of 5 mm. Up to the present, only a single hairpin loop has been used as a filament in each oscillator, but it is planned to increase the number of filaments. With an input of 25 kW into the oscillators, the anode losses amount to about 45 per cent of the input.

The voltage supply for the anode is a three-phase transformer connected to a six-phase rectifier with mercury rectifying valves. The a. c. mains are fed into the primary of the transformer through an intermediate transformer with variable ratio, the variation is carried out by remote control from the control desk. The rectifier supplies up to 5 amps at 10 000 volts, but with the single hairpin used at present as a filament in the oscillator, only about 2.5 amps can be utilized with good efficiency. In case of sparks passing over in the high tension circuit, the current through the rectifier is limited partly by wire wound resistors in the secondary of the high tension transformer and partly by an overload switch in the primary.

The coupling between the tank circuit and the oscillators is shown on Fig. 6. The tank circuit consists of two

copper tubes with 8 cm diameter and a spacing of 30 cm, made from sheet copper. A movable shorting bar allows tuning at different wavelengths. The cooling water leaving the dees is used to cool the copper tubes. The anode and grid circuits are both made from copper tubes with 2 cm diameter. Mycalex condensers with a capacity of about 1500 cm serve to keep the anode voltage off the tank circuit.

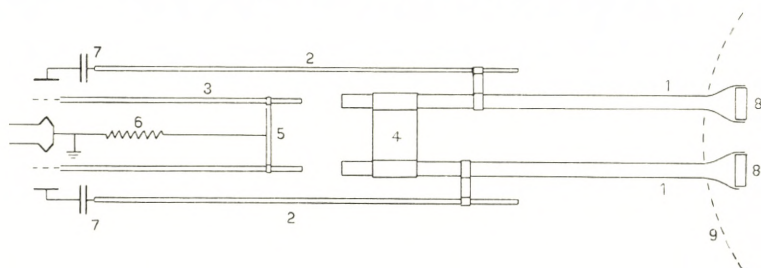

Fig. 6. 1 tank circuit, 2 anode circuit, 3 grid circuit, 4 and 5 shorting bars, 6 grid leak, 7 coupling condensers, 8 flange on dee insulator, 9 edge of magnet coil.

The voltage supply for the anodes is connected through choke coils. The grid leak of about 1500 ohms is made from a glass tube with flowing water and carbon electrodes.

The anode line is connected to the tank circuit at such a distance from the shorting bar that the proper excitation of the anodes is obtained. The voltage node of the tank circuit is not at the middle of the shorting bar, so that the connections from the tank circuit must be displaced somewhat along the tank line in order to obtain the same excitation of the anodes.

Disregarding for a moment the grid circuit, the arrangement contains two circuits, an anode circuit and a tank circuit, which are coupled tightly together. As a consequence of the tight coupling, the system has two modes of oscillations with different frequencies and different ampli-

tudes. By moving the shorting bar of the grid circuit it is possible to select an oscillation which gives a large amplitude in the tank circuit. Under given circumstances, for instance if a spark is drawn from the tank circuit, the system may "jump" into the other mode of oscillation, which gives a much smaller amplitude in the tank circuit and also a different wavelength. The "jumping" between two different modes of oscillation disturbs very little in the actual work with the cyclotron; in this connection it may be mentioned that, as a consequence of the existence of two resonance frequencies, the oscillations of the tank circuit cannot be represented exactly by a simple sin-wave.

While the plant was still under development, it was tried to have the tank circuit and the anode circuit as resonant circuits tuned to the same frequency and coupled through an untuned transmission line. It was soon found, however, that to obtain sufficient energy transfer to the tank circuit the coupling had to be made so tight that the resonance frequency of the anode and tank circuits would split into two frequencies with the same possibility of "jumping" as for the system described above. It was then preferred to use the present system which, apart from the grid circuit, does not contain any circuits which have to be tuned together.

### The Tank.

The two steel plates of 4 cm thickness, which form the top and bottom of the tank, are bolted to the main pole piece by 16 bolts uniformly distributed near the edge. As a consequence, the seal between the cylindrical wall of the tank and the top and bottom plate must be made with

the tank placed between the magnet poles. The removable part of the tank is a brass ring with the same outside diameter as the cylindrical part of the pole pieces; the height of the ring is 88 mm, the wall thickness is 15 mm. The ring is of cast brass; several leaks due to pores in the casting were found and finally tightened by painting the whole ring with glyptal. The ring and the adjacent

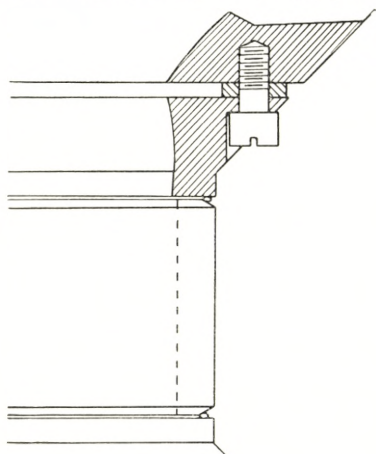

Fig. 7.

parts of the pole pieces are shown in section in Fig. 7. The ring is kept in position by four brass pieces (not shown in the figure) which are bolted both to the ring and the pole pieces. The upper and lower end of the ring are slightly conical against the outside; into the slit thus formed between the brass ring and the pole piece a rubber string (ordinary rubber insulated flex) is pressed and the joint is painted with glyptal.

The joint is easily made and has never given rise to trouble. An obvious advantage of this method of assembling the tank is, that the magnetic field remains unchanged when the tank is withdrawn from the gap, so that the properties of the field as regards homogeneity and symmetry can be examined before the tank is brought into position. Further, if a suitable arrangement of shims has once been found, the shims can be left in the shimming gap, when a removal of the tank for repair becomes necessary. Only a prolonged experience and a comparison with the results of other workers can show whether this method of assem-

bling the tank is ultimately to be preferred; here it can only be stated that no difficulty has been encountered in making the seal between the ring and the top and bottom plates in the way described here.

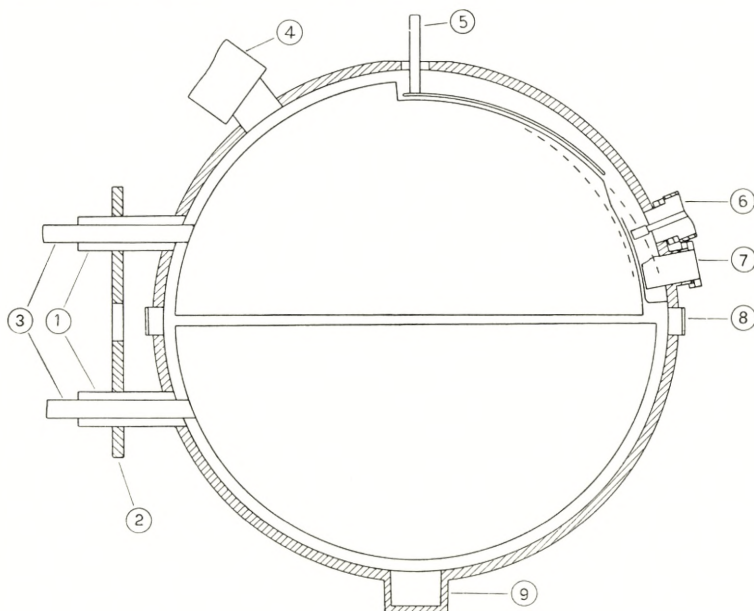

Fig. 8. 1 brass tubes, 2 brass plate, 3 dee supports, 4 pump line, 5 deflecting electrode, 6 vacuum lock, 7 irradiation pot, 8 window, 9 filament support.

The tank with the dees and the deflecting system is shown in Fig. 8. The dee insulators, which should be placed to the left of the tank in Fig. 8, are shown in detail in Fig. 10.

The studs for the dee supports, the pumping line, windows etc. are either brazed or tin-soldered in the ring. As a support for the dee insulators, two brass tubes (1) of 6 cm diameter are brazed to the tank wall, the brass tubes support a brass plate (2), into which bolts are screwed

which serve for the adjustment of the dees. The brass tubes extend 2 cm beyond the brass plate, the ends of the tubes being used as a seat for the flange carrying the insulator.

The pumping system is a 5-inch oil pump backed by a 2-inch oil pump and a mechanical pump. The pump line is a copper tube with 13 cm diameter and a length of 90 cm. Between the pump line and the pump a large valve is placed which allows of separating the pumps from the tank. The pumping speed of the pumping system itself is about 100 litres of air per second, but the pump line does not allow a speed of more than 50 litres per second. At the joint between the pump line and the brass ring, the diameter of the pump line cannot exceed 7.5 cm, and this measure sets a limit to the pumping speed. The pressure is read on a McLeod gauge or an ionization gauge. For locating leaks, a hot wire gauge made from a small carbon filament lamp is generally used.

The arrangement used for deflecting the ions out from the space inside the dees follows the device worked out at Berkeley. The deflecting field increases the radius of the path of the ion beam by 15 per cent; for deuterium ions with 10 MeV. energy, a field of 80 000 volts per cm is thus necessary. Much trouble has been caused by sparks between the rod carrying the deflecting electrode and the pole piece, the sparks passing over in the direction of the magnetic field. It has never been possible to apply a potential of more than 50 000 volts to the deflecting electrode.

The beam enters the deflecting field at 38 cm distance from the centre. The outside of the tank wall being at a distance of 45 cm from the centre, the shift in the path of the beam caused by the deflecting field is insufficient to bring the beam outside the tank wall. To irradiate

samples in vacuum, a vacuum lock is used which is shown in detail in Fig. 9. For irradiation in air, an irradiation pot is used which has an aluminium window with 3 cm stopping power.

The ion source is of the usual design, where electrons from a tungsten filament ionize the gas at the centre of the cyclotron. The filament is a straight tungsten wire of 0.6 mm diameter and 4 cm length. The current for heating

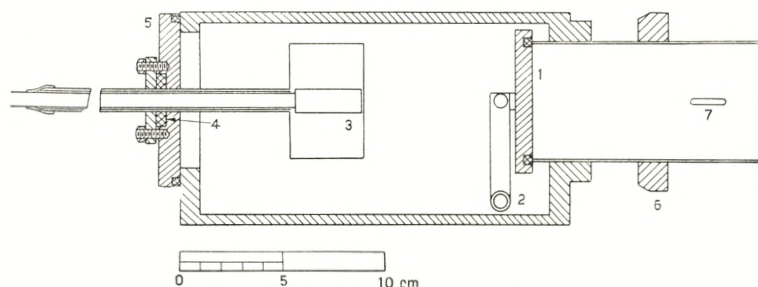

Fig. 9. 1 brass lid, 2 ground joint, 3 target holder, 4 rubber gasket, 5 external lid, 6 tank wall, 7 approximate cross section of beam.

the filament is supplied by an oscillator employing two Philips 7A/700 valves in push-pull operating at a wavelength of 300 metres. The filament forms part of a resonant circuit which by a transmission line is coupled to the oscillator. The emission drawn from the filament is usually about 200 milliamps. To accelerate the electrons, the filament is kept at a negative potential relative to ground, which can be varied continually up to 1000 volts.

The vacuum lock (Fig. 9) which is used for irradiating samples in vacuum consists of a rectangular brass box with dimensions  $7.5 \cdot 9.5 \cdot 17$  cm; the box is connected to the tank wall by a brass tube with 6 cm diameter. The separation between the box and the tank is a brass lid (1) which is moved by a ground joint (2); the lid is tightened

by a rubber gasket seated against the end of the brass tube, which projects somewhat inside the box. The sample (3) is carried by a water-cooled brass tube which slides through a rubber gasket (4), so that the sample can be moved in and out and rotated. As a lubricant for the gasket (4), castor oil is used. The gasket (4) is carried by an external lid (5) tightened by a rubber gasket. Suppose now that the lid (1) is closed and the box filled with air. To introduce a sample, the lid (5) is placed in position, and the inner end of the sample holder is pressed against the lid (1). The box is now evacuated by an auxiliary pump. When this is done, the brass tube with the target holder is pulled outwards, so that the lid (1) can be opened and the target is finally slid into position. Targets with an area of  $5 \cdot 5$  cm can be introduced through this lock.

In certain experiments, it is of importance to irradiate different samples with beams carrying exactly the same current. Experiments have been carried out with uranium, where four different samples were placed on the target holder and irradiated with deuteron beams carrying the same current, but with different energies, by rotating the target holder continuously during the irradiation. The energy of the deuterons was varied by absorbing foils placed in front of the separate targets.

### The Dees.

The dees have an outside radius of 41 cm. The top and bottom plates are spun copper plates of 1 mm thickness; along the outside the copper plates are fastened by screws to a brass ring of height 25 mm and thickness 3 mm; along the diameter a cooling pipe of 6 mm copper



tubing forms the mechanical support. The internal height at the centre is 45 mm, the height decreases nearly regularly from the centre to the outside. In view of the determinations of the movements of the ions in the cyclotron carried out by WILSON<sup>1</sup>, it would probably have been of advantage to keep the maximum height out to a distance of some 20 cm from the centre. The support for the dee is a 30 mm rod of solid copper. Four grooves are cut in the copper rod into which the cooling pipes for the dee are soldered.

The insulator supporting the dee is shown in Fig. 10. The insulator is of fused quartz ("Rotosil"); its length is 30 cm, the diameter of the end flanges is 14 cm. Brass flanges are cemented at the ends of the insulator by ordinary red sealing wax. The brass flange (1) carrying the inner end of the insulator rests with a conical seat on a brass tube (2) projecting from the tank wall and is kept in position by four bolts (3) which are fixed to a brass plate (4). Tightness between the brass flange (1) and the

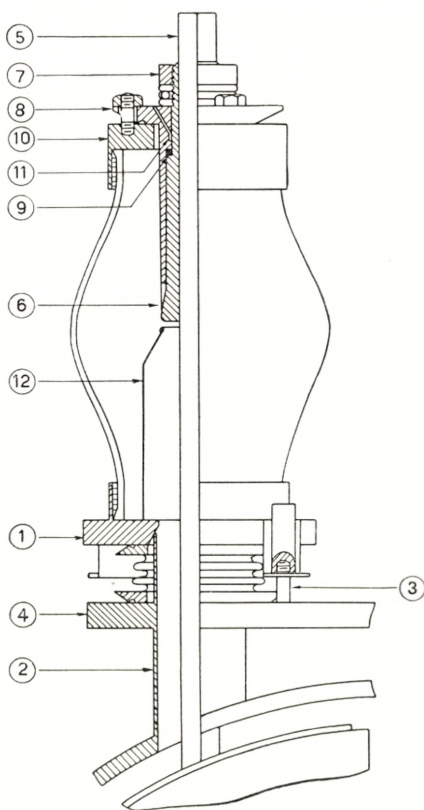

Fig. 10.

<sup>1</sup> R. R. WILSON, Phys. Rev. **53**, 408 (1938).

brass plate (4) is afforded by a bellow. By means of the bolts, the dee can be moved up and down and sideways within certain limits.

To the dee rod (5) is soldered a brass sleeve (6) which by the nut (7) is screwed together with the flange (8);

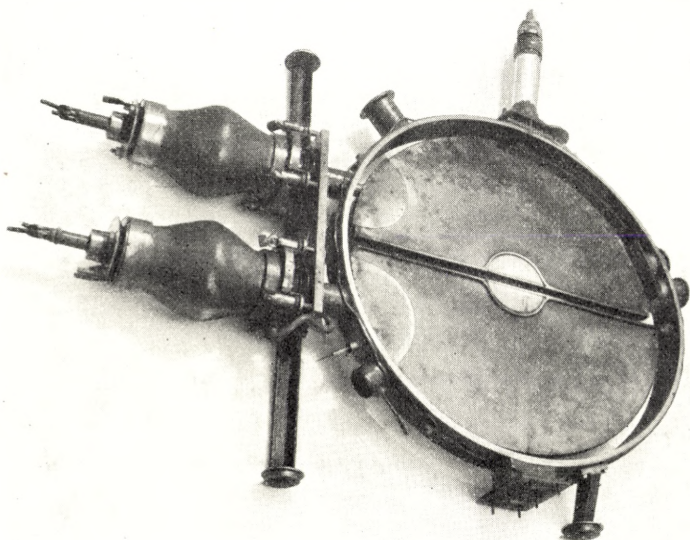

Fig. 11. The ring with the dees and insulators removed from the gap. The ring rests on four wheels, of which three are seen in the figure. The filament has been removed from its holder (lower part of the figure).

lightness between (6) and (8) is afforded by an internal rubber gaskett (9). The flange (8) is fixed to the flange (10) by three bolts in such a way that some movement of the dee rod relative to the flange is possible. A groove (11) is cut in the inner side of (8) so that a gas stream can be floated round the gaskett to control its tightness. A copper tube (12) which has its rounded end about 1 cm from the end of (6) is fixed to the flange (1) in order to shield the insulator from electric fields.

As a whole, the present construction of the dee support is hardly satisfactory. The use of four bolts for the adjustment of the dee is unsatisfactory since, to obtain a movement of the dee, all four bolts have to be moved. The sealing wax used for the connection between the insulator and the flanges is quite satisfactory as regards mechanical stability, but the cooling of the flange must of course be effective. The main reason for cementing the brass flanges to the insulator by sealing wax is that, in this way, the outside dimensions of the flange can be kept small; this is highly desirable in view of the small distance between the magnet coils. The present clearance of 5 cm between the flange and the magnet coil is sufficient to allow about 25 kW. input into the oscillator at a wavelength of 23 m without sparking.

### Working Experiences.

Most of the observations described in this section were made with deuterons of energy from 8 to 9.5 MeV.; for a short time, protons of 5 MeV. energy were used. Without presenting any essential new features, the observations may be of sufficient interest to justify a short description. With 8 MeV deuterons a beam of  $2 \mu\text{A}$  could be obtained through the deflecting field, for higher energies the beam decreased rapidly; with 9.5 MeV deuterons  $0.1 \mu\text{A}$  could be obtained. The homogeneity of the beam was examined by means of the range curves of LIVINGSTON and BETHE<sup>1</sup>.

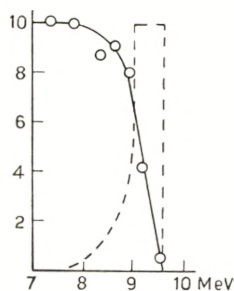

Fig. 12.

<sup>1</sup> M. S. LIVINGSTON and H. A. BETHE, Rev. Mod. Phys. 9, 226 (1937).

The result for a deuteron beam with 9.5 MeV maximum energy is shown in Fig. 12. The full curve shows the directly measured absorption of the deuterons, the dotted curve is a differential curve, showing the relative number of deuterons with a given energy.

The height of the beam after leaving the deflecting field is about 3 mm; at an early stage of the work, when the cyclotron

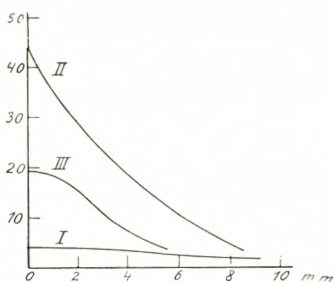

Fig. 13. Abscissa: distance from median plane. Ordinate: activity in arbitrary units. Curve I, distance from centre 20 cm. Curve II, distance from centre 30 cm. Curve III, distance from centre 35 cm.

was running with deuterons of about 5 MeV. energy, a few measurements were made of the height of the beam inside the dees. A copper wire with 3 mm diameter was placed vertically between the dees; after a short run, the distribution of activity along the wire was determined by measuring the activity through a lead slit which was placed in front of a counter. The results are shown in Fig. 13 for three

different distances between the wire and the centre of the cyclotron. The results demonstrate that for the region investigated nearly the whole activity on the wire is found within 5 mm distance from the median plane. The curves in Fig. 13 give very nearly a true representation of the amplitudes of the ions about the median plane, because the ions will spend most of the time at the maximum distance from the median plane.

From Fig. 5 it appears that a considerable change in the magnetic field can be produced by evacuating the shimming gap. Curves I and II of Fig. 5 represent roughly the limits between which the gradient of the field has been

varied. Some increase of the gradient could be produced by pyramid shims in the shimming gap. Several such arrangements were tried, but the result was that, although the beam was extremely sensitive to an asymmetry of the field about the median plane, only very slight changes of the beam could be produced by changing the gradient of the field. At the same time, it was found that a considerable increase of the beam could be produced by a sort of azimuthal shimming, where rectangular slabs of iron were placed mainly in the outer region of the upper shimming gap. By a suitable arrangement of three or four such slabs, the beam current could usually be increased roughly a hundred times. The action of this sort of shimming is probably to direct the beam through the deflection channel or, in other words, to shift the paths of the high energy ions in such a way as to bring the centre of the circulating ion beam to coincide with the geometrical centre.

To control the dee voltage, a circular disk with 1 cm diameter is inserted in the tank wall, insulated by a pyrex tube; the disk is connected to a rectifier in the manner described by WHITMER<sup>1</sup>. This voltmeter gives only relative values of the dee voltage, and its reading further depends somewhat on the position of the dee; it has been very useful, however, in connection with the adjustment of the oscillator.

To obtain an absolute measure of the dee voltage, the dee circuit is disconnected from ground and the position of the filament is changed, so that it is below one of the dees. With the filament in this position, the dee circuit collects a negative charge until its potential is equal to the peak voltage, and this potential is measured with a voltmeter

<sup>1</sup> R. M. WHITMER, *Rev. Sc. Instr.* 10, 165, 1939.

with a high resistance. Corresponding to an input of 22 kW into the oscillators, a voltage difference of 35 kV peak value between the dees was found. This result may seem rather low in comparison with the value given by other workers<sup>1</sup> employing similar dee circuits. An explanation of the difference may be found in the present construction of the dee support which, probably, offers a relatively high resistance to the high frequency current. The smallness of the height of the beam mentioned above may be brought into connection with the relatively low value of the dee voltage. The reason for the insensitivity of the beam against changes in the gradient of the magnetic field then remains somewhat obscure. Unless the gradient of the field, which is necessary to give a reasonable increase in the beam current, must fulfill very special conditions, which can only be found out by pure chance, the beam current is only slightly dependent on the gradient of the field, as stated above.

The screening against neutrons has been accomplished in a simple way by placing paraffin blocks in the gap between the magnet coils. The paraffin blocks together with the oil tanks containing the coils constitute an enclosure of about 45 cm thickness, which is sufficient for the purpose, at least with the neutron intensities hitherto obtained.

On several occasions, it was noticed that the beam, which was obtained momentarily by letting the magnetic field sweep through the resonance value, was much stronger with decreasing than with increasing field. A similar observation has been made by HENDERSON and WHITE<sup>2</sup> who

<sup>1</sup> ALLEN, SAMPSON and FRANKLIN, *Journ. Franklin Inst.* **228**, 543 (1939). HENDERSON, KING, RISSER, YEARIAN and HOWE, *Journ. Franklin Inst.* **228**, 563, (1939).

<sup>2</sup> M. C. HENDERSON and M. G. WHITE, *Rev. Sc. Instr.* **9**, 19 (1938).

explain the effect as being due to eddy currents in the pole pieces, induced by the changing flux. Besides this effect which undoubtedly is present, another effect has been noticed which may be of even more influence on the gradient of the field, viz. relatively large movements of the top and

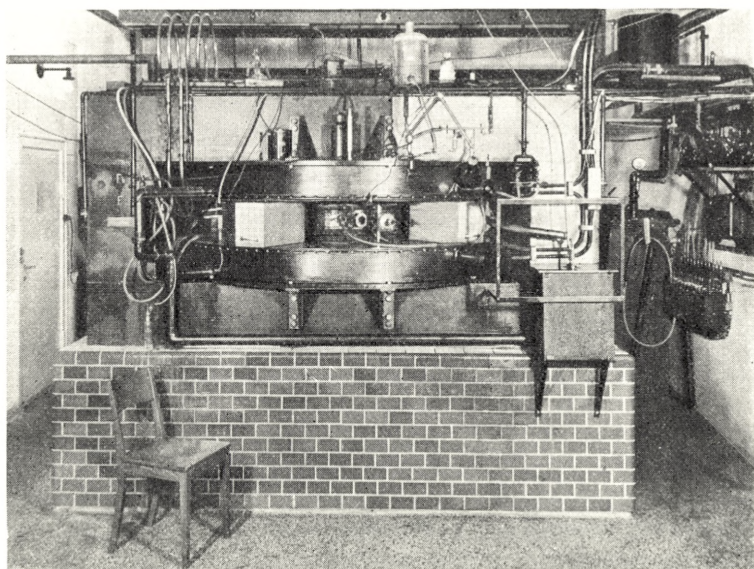

Fig. 14. The magnet seen from the side opposite the oscillator. Near the centre of the figure the vacuum lock and the irradiation pot can be distinguished. The paraffin blocks used for screening against neutrons have been partly removed.

bottom plates of the tank when the field is changing. This effect was noticed during some measurements of the bending of the top plate of the tank due to atmospheric pressure. For these measurements, a simple mechanical device was used, which transferred the movements of the top plate to a mirror, so that the width of the shimming gap could be read on a scale. When the field was changing, movements of the top plate were observed which, in some cases,

were larger than the shift of 0.18 mm caused by the air pressure of 6 tons. No detailed study of this effect was carried out but, from the observed magnitude of the displacements, it was estimated that the effect on the gradient of the field was comparable with the effect due to the atmospheric pressure on the top and bottom plates.

In concluding this account I wish to thank the director of the Institute, Professor N. BOHR, for his continual interest and helpful advice. Special thanks are also due Director V. MEYER from the Thrige factories, who planned the magnet and several parts of the electrical equipment. During the construction of the cyclotron much help was given by Dr. O. R. FRISCH, Mr. S. HØFFER-JENSEN, Mr. N. O. LASSEN and, especially, by Dr. L. J. LASLETT, whose skill and experience were of invaluable help for our work during his stay in Copenhagen. Acknowledgements are further due Mr. H. W. OLSEN and his collaborators in the institute workshop for the excellent elaboration of the many often complicated pieces of the apparatus.